

2. INSTALLATION DATA

2.1 ABE

Self-drilling screw - hexagonal head with embossed washer



Properties



Steel



Zinc-plated coating



Available in different colours

Base material



Plate assembly



Plate profile

Properties



Hexagonal with embossed washer



Hexagonal with embossed washer



Screw point

Installation data

CODE		ST 3.5	ST 4.2	ST 4.8	ST 5.5	ST 6.3
d_k : washer head diameter	[mm]	8	8.5	10	10.5	12.6
k : head thickness	[mm]	3.3	4.1	4.3	4.3	6.3
c : washer thickness	[mm]	1.2	1.5	1.6	1.9	2
s : spanner	[mm]	6	7	8	8	10
D : exterior thread diameter	[mm]	3.53	4.22	4.80	5.46	6.25
d : interior thread diameter	[mm]	2.64	3.10	3.58	4.17	4.88
p : thread	[mm]	1.3	1.4	1.6	1.8	1.8
l : lengths	[mm]	9.5 - 32	13 - 38	13 - 38	19 - 75	19 - 240
Installation bit code (hexagonal magnetic bit)		BOCA006	BOCA007	BOCA008	BOCA008	BOCA010
Drill capacity	[mm]	0.70 - 2.25	1.75 - 3.00	1.75 - 4.40	1.75 - 5.25	2.50 - 6.00

DRAWING

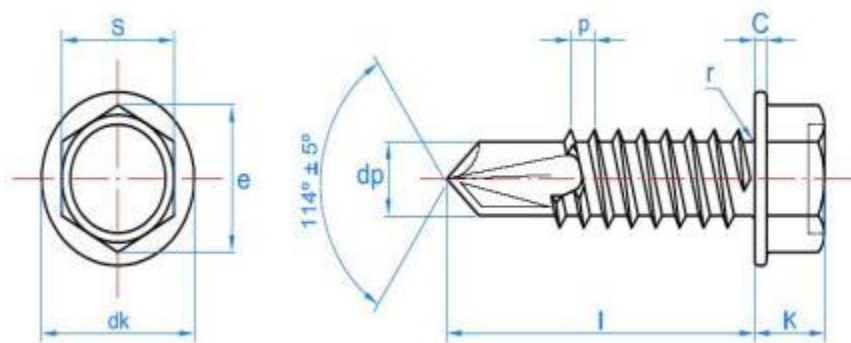

- Zinc-plated finish.
- For general plate-plate joints.
- Versions with assembled EPMD washer for sealed joints in façades and roofing (consult ARVUL Technical Data Sheet).

